

DIESEL BURNER
OPERATION MANUAL
BTN40-55-85-120-150-210-250LR





C O N T E N T S

| | |
|--|----|
| 1. BRIEFNESS | 1 |
| 2. ANNOUNCEMENTS | 2 |
| 3. SAFETY AND PROTECTION | 5 |
| 4. TECHNICAL DATA | 6 |
| 4.1. SUMMARY | |
| 4.2. TECHNICAL PARAMETERS | |
| 4.3. STANDARD FITTINGS DIAGRAM | |
| 4.4. BURNER OUTLOOK DIMENSION DIAGRAM | |
| 4.5. WORKING RANGE CURVE | |
| 5. BURNER OPERATION | 11 |
| 5.1. BURNER INSTALLATION | |
| 5.2. OIL PIPELINE CONNECTION | |
| 5.3. CIRCUIT CONNECTION | |
| 5.4. OIL SUPPLY DIAGRAM | |
| 5.5. PUMP | |
| 6. BURNER HEAD SETTING | 15 |
| 6.1. CONTROLLING PANEL | |
| 6.2. ONE STAGE FIRE BURNER BTN40L WORKING PRINCIPLE | |
| 6.3. TWO STAGE FIRE BURNER BTN40-250LR WORKING PRINCIPLE | |
| 7. BURNER HEAD SETTING | 18 |
| 7.1. BTN40-55LR AIR ADJUSTMENT IN BURNER HEAD | |
| 7.2. BTN85-250LR AIR ADJUSTMENT IN BURNER HEAD | |
| 7.3. REMOVING OIL SPRAYER | |
| 7.4. ELECTRODE LOCATION ADJUSTMENT | |
| 7.5. AIR DAMPER ADJUSTMENT MECHANISM | |
| 8. CONTROLLING SYSTEM | 21 |
| 8.1. LOA24...OIL CONTROLLING SYSTEM | |
| 8.2. LMO...CONTROLLER | |
| 9. MAINTENANCE | 27 |
| 10. FAILURE AND MEASUREMENTS | 28 |
| 11. WIRING DIAGRAM | 31 |

1. BRIEFNESS

BTN40-55 L is full automatic one stage fire light oil burner;

BTN40-55-85-120-150-210-250LR is full automatic two stage fire light oil burner;

These burners could be used for many heating devices:like hot water oven, steam boiler and air heater etc.

Fuel:

Light oil - heating value: $H_i=42.7\text{MJ/kg}=10200\text{kcal/kg}$

Burner has fan motor which provides enough air to support fuel burning well by enough high and stable pressure.

Supply fuel oil(light oil)Max. viscosity at 20 °C: 6 mm²/s (1.5 °E - 6 cSt)

Oil should be filtered before going to burner pump.Max. gridding is 125µm.

light oil input pressure was set by supplier;please refer to the 《Pump》 section.

Burner adjustment ratio is 1:2(except BT18.26.35L).

Max.supporting-combustion air flow: Need 15m³air per 1kg.

Burner controller detects burner work all times.

Boiler temperature/pressure controls burner load.

IP40

Control voltage: 230V (-15%...+10%)50HZ, Single-phase electricity

BT40□ 55LR Supply voltage: 230V/50HZ, ngle-phase electricity.

BT85□ 120□ 150□ 210□ 250LR Supply voltage: 380V/50HZ, ngle-phase electricity.

The prerequisite of burner operation: Ambient temperature is 0...+40°C.

Check below items before first start burner:

Connection(motor turning direction)

Adjustment and controlling system set

Boiler and other equipments under working.

Burner can get enough air

Open supply valve

There has enough oil in oil tank

Enough oil temperature, its viscosity is 4-12mm²/S(Max.+60°C)

Take burner and boiler supplier `s instruction for reference.

2. ANNOUNCEMENTS

2.1. Introduction

The instruction manual supplied with the burner :



- Is an integral and essential part of the product and must not be separated from it; it must therefore be kept carefully for any necessary consultation and must accompany the burner even if it is transferred to another owner or user, or to another system. If the manual is lost or damaged,
- another copy must be requested from the Technical Assistance Service of the area ;
- Is designed for use by qualified personnel ;
Offers important indications and instructions relating to the installation safety, start-up, use and maintenance of the burner.

Symbols used in the manual :



In some parts of the manual you will see triangular DANGER signs. Pay great attention to these, as they indicate a situation of potential danger.









2.2. General dangers

The dangers can be of 3 levels, as indicated below.

| | |
|---|---|
|  DANGER | <p>Maximum danger level! This symbol indicates operations which, if not carried out correctly, cause serious injury, death or long-term health risks.</p> |
|  WARNING | <p>This symbol indicates operations which, if not carried out correctly, may cause serious injury, death or long-term health risks.</p> |
|  CAUTION | <p>This symbol indicates operations which, if not carried out correctly, may cause damage to the machine and/or injury to people.</p> |

2.3. Other symbols

| | |
|--|--|
|  DANGER | <p>DANGER: LIVE COMPONENTS This symbol indicates operations which, if not carried out correctly, lead to electric shocks with lethal consequences</p> |
|  | <p>DANGER: FLAMMABLE MATERIAL This symbol indicates the presence of flammable materials.</p> |

| | |
|---|--|
|  | <p>DANGER: CRUSHING OF LIMBS</p> <p>This symbol indicates the presence of moving parts; danger of crushing of limbs.</p> |
|  | <p>WARNING: MOVING PARTS</p> <p>This symbol indicates that you must keep limbs away from moving mechanical parts; danger of crushing.</p> |
|  | <p>DANGER: EXPLOSION</p> <p>This symbol signals places where an explosive atmosphere may be present. An explosive atmosphere is defined as a mixture - under atmospheric conditions - of air and flammable substances in the form of gases, vapours, mist or dust in which, after ignition has occurred, combustion spreads to the entire unburned mixture.</p> |
|  | <p>PERSONAL PROTECTION EQUIPMENT</p> <p>These symbols indicate the equipment that must be worn and kept by the operator for protection against threats against safety and/or health while at work.</p> |
|  | <p>OBLIGATION TO ASSEMBLE THE COVER AND ALL THE SAFETY AND PROTECTION DEVICES</p> <p>This symbol signals the obligation to reassemble the cover and all the safety and protection devices of the burner after any maintenance, cleaning or checking operations.</p> |
|  | <p>ENVIRONMENTAL PROTECTION</p> <p>This symbol gives indications for the use of the machine with respect for the environment.</p> |
|  | <p>IMPORTANT INFORMATION</p> <p>This symbol indicates important information that you must bear in mind.</p> |
|  | <p>This symbol indicates a list.</p> |

2.4. Guarantee and responsibility

The manufacturer guarantees its new products from the date of installation, in accordance with the regulations in force and/or the sales contract. At the moment of the first start-up, check that the burner is integral and complete.

| | |
|---|--|
|  | Failure to observe the information given in this manual, operating negligence, incorrect installation and carrying out of non authorised modifications will result in the annulment by the manufacturer of the guarantee that it supplies with the burner. |
|---|--|

In particular, the rights to the guarantee and the responsibility will no longer be valid, in the event of damage to things or injury to people, if such damage/injury was due to any of the following causes:

- Incorrect installation, start-up, use and maintenance of the burner;
- Improper, incorrect or unreasonable use of the burner;
- Intervention of unqualified personnel;
- Carrying out of unauthorised modifications on the equipment;
- Use of the burner with safety devices that are faulty, incorrectly applied and/or not working;
- Installation of untested supplementary components on the burner;
- Powering of the burner with unsuitable fuels;
- Faults in the fuel supply system;
- Continuation of use of the burner when a fault has occurred;
- Repairs and/or overhauls incorrectly carried out;
- Modification of the combustion chamber with inserts that prevent the regular development of the structurally established flame;
- Insufficient and inappropriate surveillance and care of those burner components most likely to be subject to wear and tear;
- Use of non-original components, including spare parts, kits, accessories and optional;
- Force majeure.

The manufacturer furthermore declines any and every responsibility for the failure to observe the contents of this manual.

3. SAFETY AND PROTECTION

3.1. Introduction

The burners have been designed and built in compliance with current regulations and directives, applying the known technical rules of safety and envisaging all the potential danger situations. It is necessary, however, to bear in mind that the imprudent and clumsy use of the equipment may lead to situations of death risk for the user or third parties, as well as the damaging of the burner or other items. Inattention, thoughtlessness and excessive confidence often cause accidents; the same applies to tiredness and sleepiness.

It is a good idea to remember the following:

- The burner must only be used as expressly described. Any other use should be considered improper and therefore dangerous.

In particular:

it can be applied to boilers operating with water, steam, diathermic oil, and to other uses expressly foreseen by the manufacturer;

the type and pressure of the fuel, the voltage and frequency of the electrical power supply, the minimum and maximum deliveries for which the burner has been regulated, the pressurisation of the combustion chamber, the dimensions of the combustion chamber and the room temperature must all be within the values indicated in the instruction manual.

- Modification of the burner to alter its performance and destinations is not allowed.
- The burner must be used in exemplary technical safety conditions. Any disturbances that could compromise safety must be quickly eliminated.
- Opening or tampering with the burner components is not allowed, apart from the parts requiring maintenance. □
- Only those parts envisaged by the manufacturer can be replaced.

| | |
|---|---|
|  | <p>The manufacturer guarantees safety and proper functioning only if all burner components are intact and positioned correctly.</p> |
|---|---|

3.2. Personnel training

The user is the person, body or company that has acquired the machine and intends to use it for the specific purpose. He is responsible for the machine and for the training of the people working around it.

The user:

- undertakes to entrust the machine exclusively to suitably trained and qualified personnel;
- undertakes to inform his personnel in a suitable way about the application and observance of the safety instructions. With that aim, the user undertakes to ensure that everyone knows the use and safety instructions for his own duties.
- Personnel must follow all the danger and caution indications shown on the machine.
- Personnel must not carry out, on their own initiative, operations or interventions that are not within their province.
- Personnel are obliged to inform their superiors of every problem or dangerous situation that may arise.
- The assembly of parts of other makes, or any modifications, can alter the characteristics of the machine and hence compromise operating safety. The manufacturing company therefore accepts no responsibility whatsoever for any which may result from the use of non-original parts.

In addition:



Must take all the measures necessary to prevent unauthorised people gaining access to the machine;

- The user must inform the manufacturer if faults or malfunctioning of the accident prevention systems are noticed, along with any presumed danger situation;
- Personnel must always use the personal protective equipment envisaged by legislation and follow the indications given in this manual.



4. TECHNICAL DATA

4.1. Summary

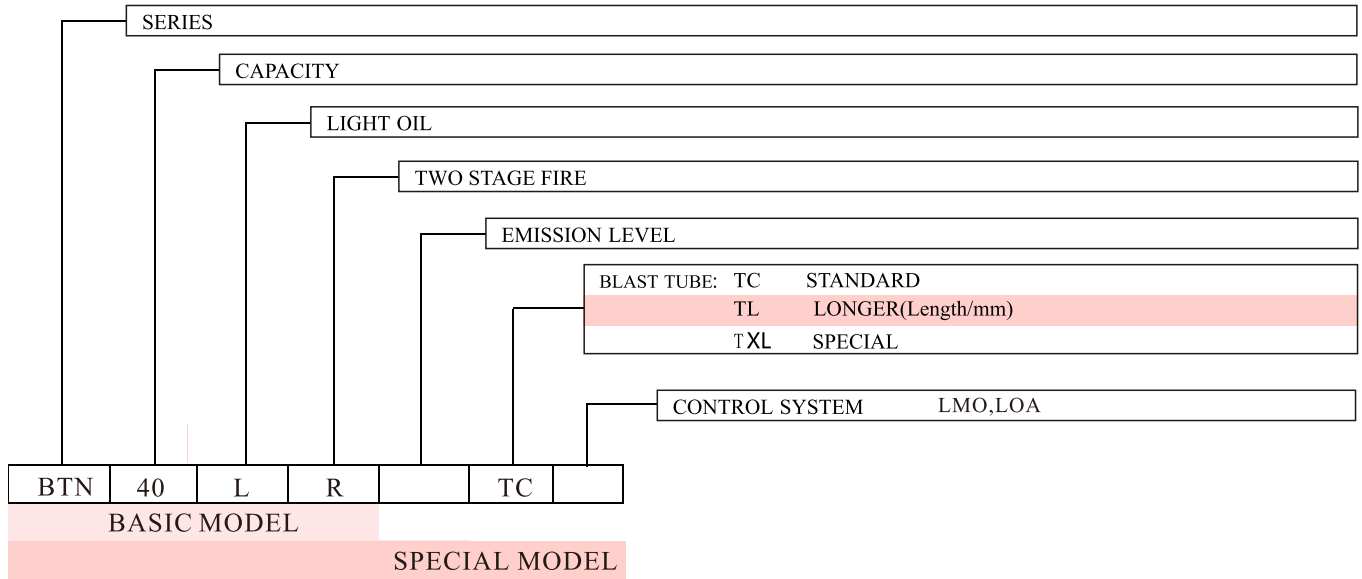

- Two stage fire (high/ low fire)
- Controlling is easy way.
- High pressure mechanical atomisation of fuel using nozzle.
- Hinge-joint connection, it is easy for maintenance .
- Controlling system is with burner together
- There has plug connector in circuit inlet.
- Modulation device (if necessary)

4.2. Technical Parameters

| BURNER | BTN40L/LR | BTN55L/LR | BTN85LR | BTN120LR | BTN150LR | BTN210LR | BTN250LR |
|----------------------|--------------------|--------------------|--------------------|--------------------|--------------------|--------------------|--------------------|
| Output KW | 97~395 | 155~480 | 255~830 | 356~1186 | 486~1540 | 543~2443 | 600~2700 |
| Kg/h | 9.24~33.2 | 13.02~40.34 | 21.43~69.75 | 29.92~99.67 | 40.84~19.41 | 45.63~205.3 | 50.42~226.9 |
| Burner motor Voltage | 230V-50Hz | 230V-50Hz | 380V-50Hz | 380V-50Hz | 380V-50Hz | 380V-50Hz | 380V-50Hz |
| Frequency | | | | | | | |
| Output KW | 0.45 | 0.45 | 1.1 | 1.5 | 2.2 | 4.5 | 7.5 |
| Current A | 2850 | 2850 | 2850 | 2850 | 2850 | 2850 | 2850 |
| Rpm | | | | | | | |
| Controller | LMO.. | LMO... | LMO... | LMO... | LMO... | LMO... | LMO... |
| Photocell | QRB... | QRB... | QRB... | QRB... | QRB... | QRB... | QRB... |
| - Oil input | G ^{1/2} " | G ^{1/2} " | G ^{1/2} " | G ^{1/2} " | G ^{1/2} " | G ^{3/4} " | G ^{3/4} " |
| - Oil return | G ^{1/2} " | G ^{1/2} " | G ^{1/2} " | G ^{1/2} " | G ^{1/2} " | G ^{3/4} " | G ^{3/4} " |
| Weight/kg | 22 | 22 | 45.5 | 52.5 | 56.5 | 86 | 86 |

4.3 STANDARD FITTINGS DIAGRAM

BTN40-55LR

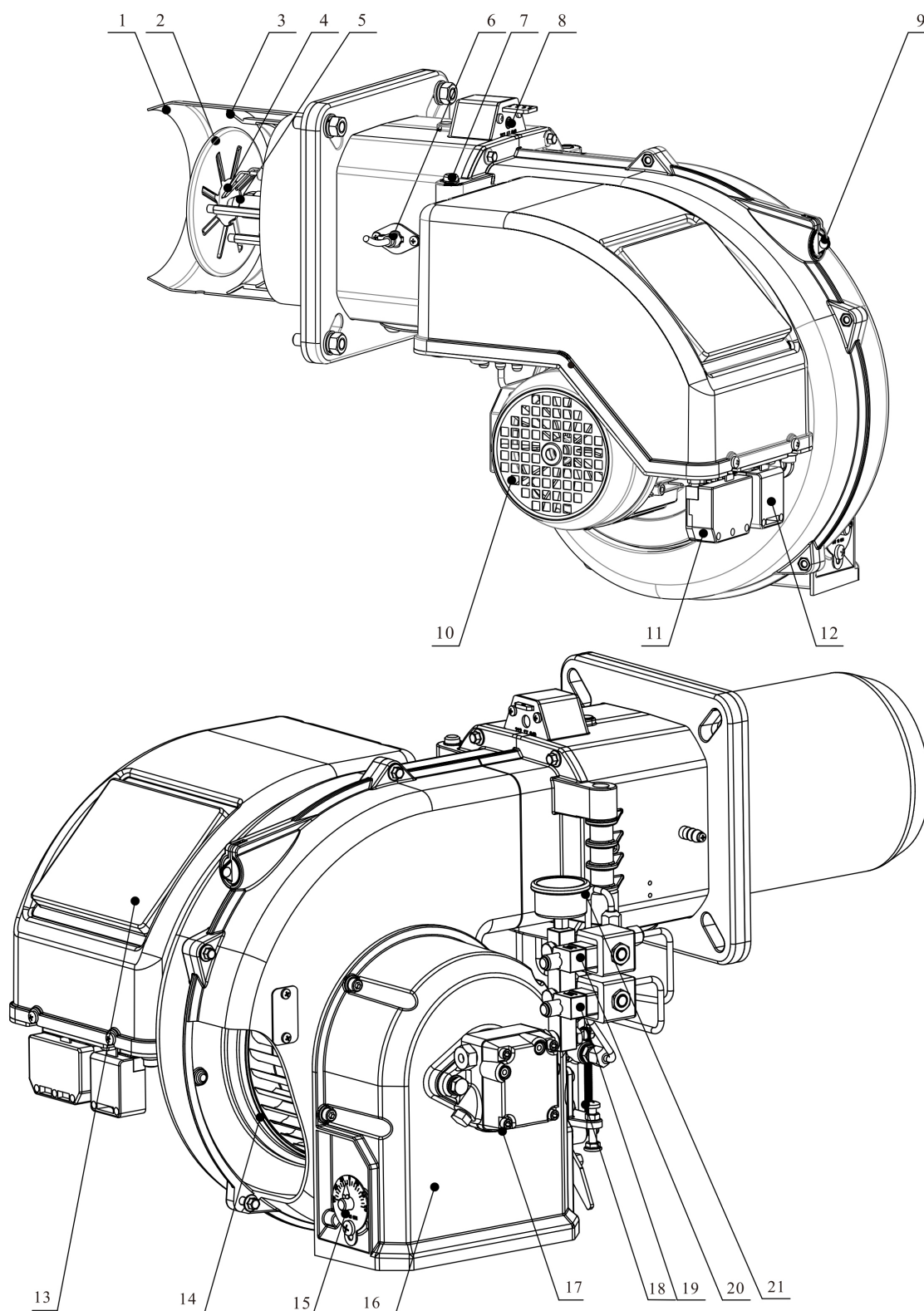

- | | | | | |
|-----------------|-------------------|------------------|-----------------------|-----------------------------|
| 1. Blast tube | 5. Nozzle | 9. Watch mirror | 13. Controlling panel | 17. Pump |
| 2. Air diffuser | 6. Photocell | 10. Motor | 14. Impeller | 18. Hydraulic cylinder |
| 3. Shutter | 7. Hinge axis | 11. 7pins socket | 15. Air damper notch | 19. 1st fire solenoid valve |
| 4. Electrode | 8. Adjustment nut | 12. 4pins socket | 16. Air damper plate | 20. 2nd fire solenoid valve |

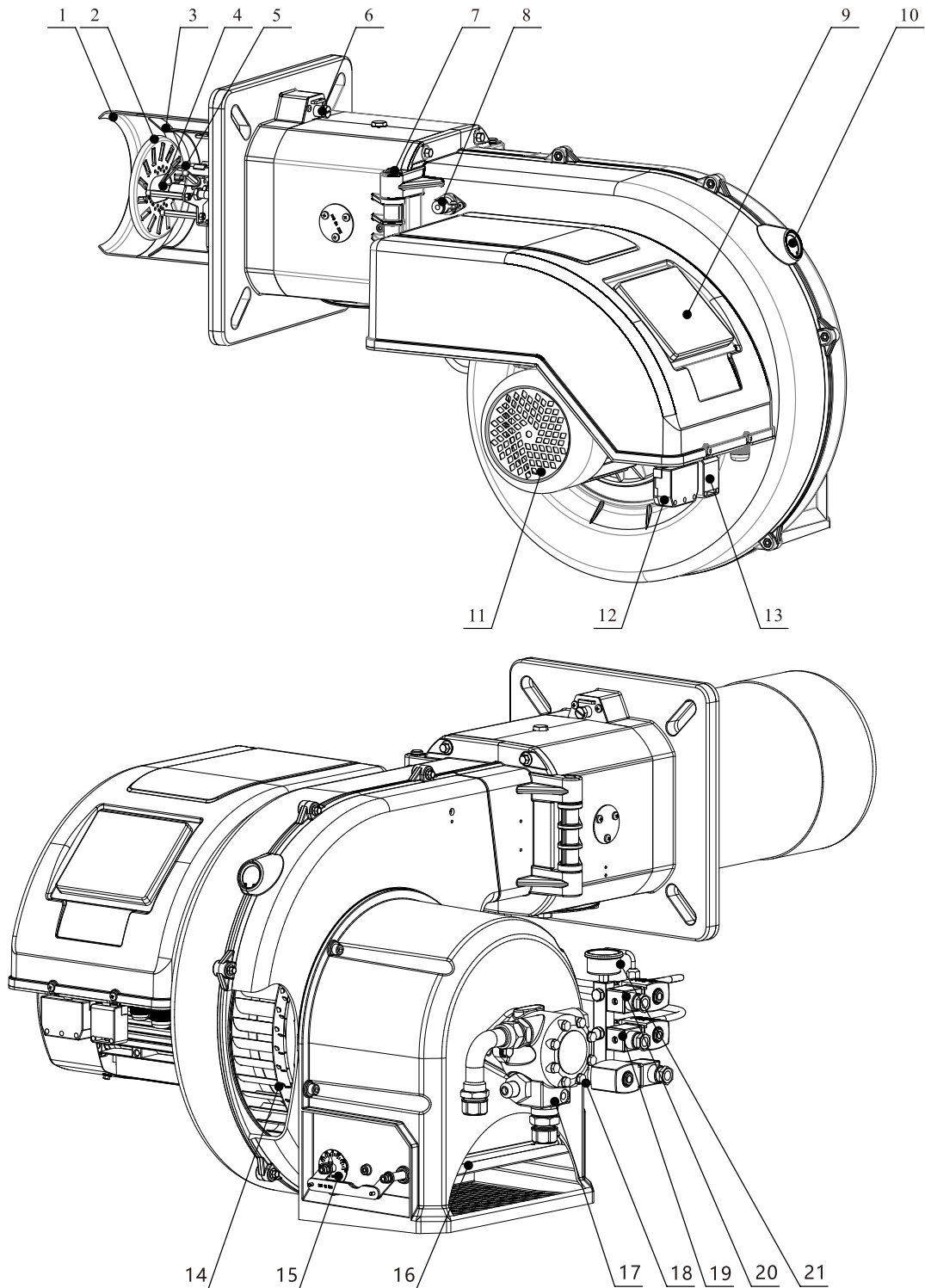

- | | | | |
|-----------------|----------------------|----------------------|-----------------------------|
| 1. Blast tube | 6. Adjustment nut | 11. Motor | 16. Air damper plate |
| 2. Air diffuser | 7. Hinge axis | 12. 7pins socket | 17. Pump |
| 3. Shutter | 8. Photocell | 13. 4pins socket | 18. Hydraulic cylinder |
| 4. Nozzle | 9. Controlling panel | 14. Impeller | 19. 1st fire solenoid valve |
| 5. Electrode | 10. Watch mirror | 15. Air damper notch | 20. 2nd fire solenoid valve |

4.4.BURNER OUTLOOK DIMENSION DIAGRAM

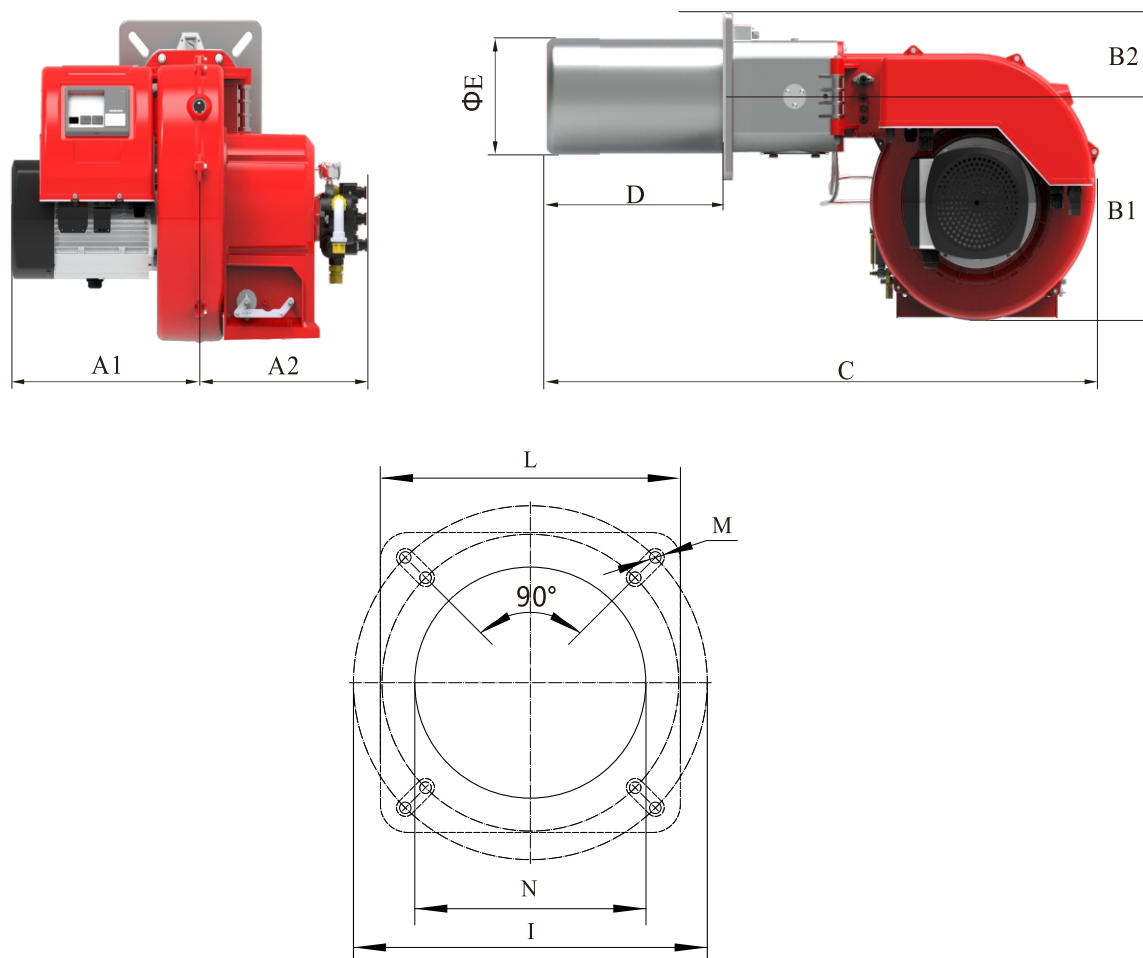

| Modle | A1 | A2 | B1 | B2 | C | D | E | I | L | M | N |
|-----------|-----|-----|-----|-----|------|-----|-----|---------|-----|-------|-----|
| | mm | mm | mm | mm | mm | mm | Φmm | Φmm | mm | M | Φmm |
| BTN40L/LR | 253 | 215 | 297 | 110 | 693 | 210 | 160 | 218~260 | 220 | 4-M10 | 170 |
| BTN55L/LR | 253 | 215 | 297 | 110 | 693 | 210 | 160 | 218~260 | 220 | 4-M10 | 170 |
| BTN85LR | 355 | 325 | 428 | 160 | 1042 | 250 | 180 | 290~370 | 320 | 4-M16 | 190 |
| BTN120LR | 355 | 335 | 428 | 160 | 1042 | 250 | 180 | 290~370 | 320 | 4-M16 | 190 |
| BTN150LR | 355 | 335 | 428 | 160 | 1072 | 280 | 190 | 290~370 | 320 | 4-M16 | 200 |
| BTN210LR | 390 | 400 | 428 | 160 | 1162 | 370 | 222 | 290~370 | 320 | 4-M16 | 232 |
| BTN250LR | 445 | 400 | 428 | 160 | 1162 | 370 | 222 | 290~370 | 320 | 4-M16 | 232 |

4.5.WORKING RANGE CURVE

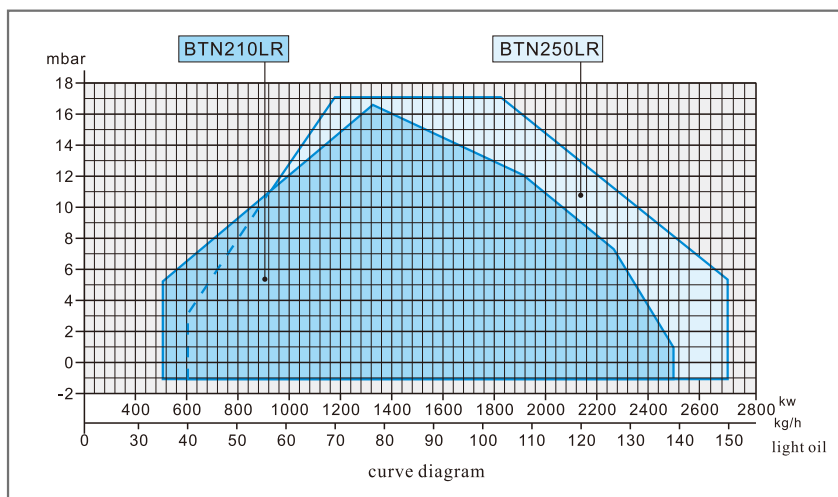
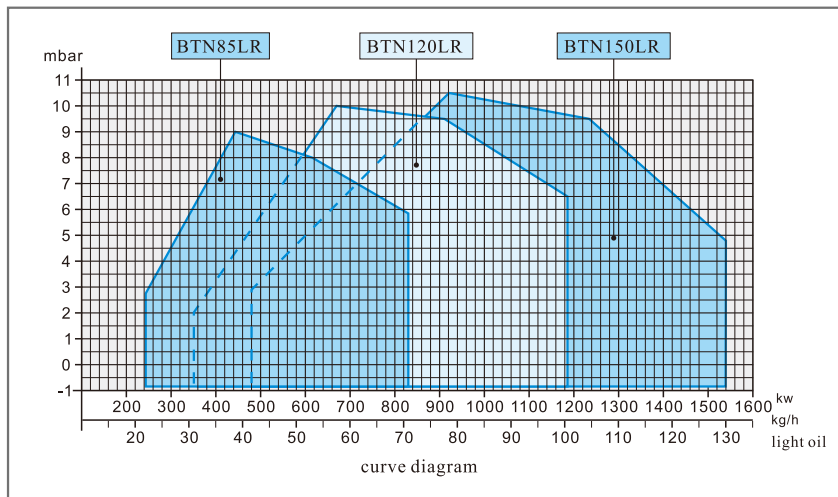
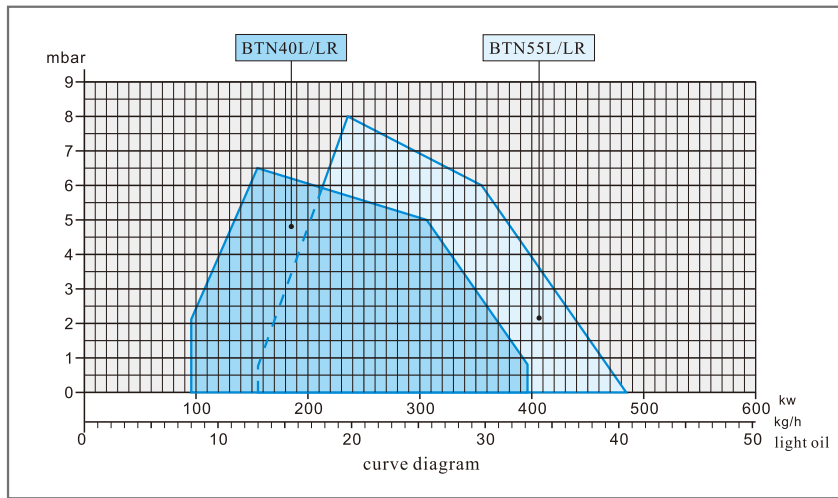

Comparing with burning output of chamber pressure that is the Max. value under ideal test. All data is base on 20°C air temperature and 500meters altitude .

Besides,the chamber resistance will increase 1.3times more during smoke recycle system.

5. BURNER OPERATION

5.1. Burner Installation

Preparation before installation

1. Check chimney (sectional area and height).
2. Voltage and frequency.
3. Oil system and dimension, there must have ball valve switch pipeline accessory before oil pipeline filtering system.
4. Check burner accessory.
5. There has filter in oil intake pipe.
6. Rust clear inside pipe.

Installation

1. Put gasket inside boiler between mounting board and flange, use double head bolt and six angle screw to fasten. After taking burner head and tube into combustion chamber, fasten the bolt, fix burner. There must be seal among boiler board, gasket and mounting flange. No air leak in case that the heating smoke will reduce heating reaction or damage spare parts during running.
2. Connect fuel oil to pump refer to supply oil return system diagram.
3. Connect circuit.

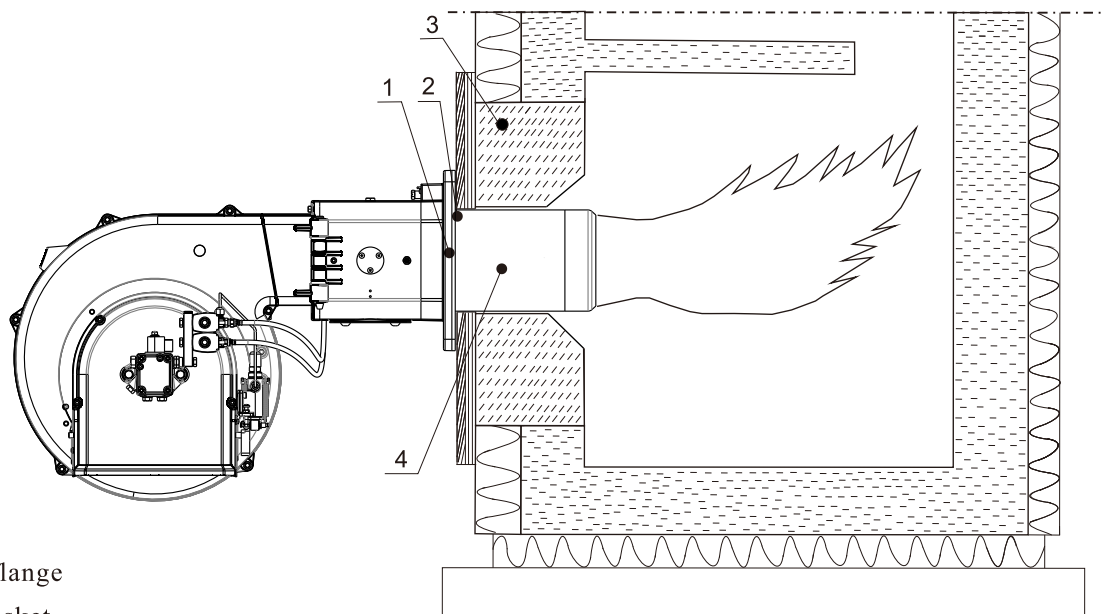

1. Mounting flange
2. Asbestos gasket
3. Fire-Proof material
4. Burner head

Note: Installation board must have standard burner mounting flange "M" thread hole dimension, please install burner refer to diagram. □

5. 2. OIL PIPELINE CONNECTION

Burner has two pipeline system: oil supply and oil return.

Oil supply pipeline must have filter system.

Note! There must install manual stop valve before adjustment equipment.

Oil pipe exhausts

Connect flexible hose,open oil supply ball valve,make oil flows to filer and pump inlet.

Start burner.When exhaust, loose pump "P" screw or filter waste screw, until gas flow well. then fasten the screw.

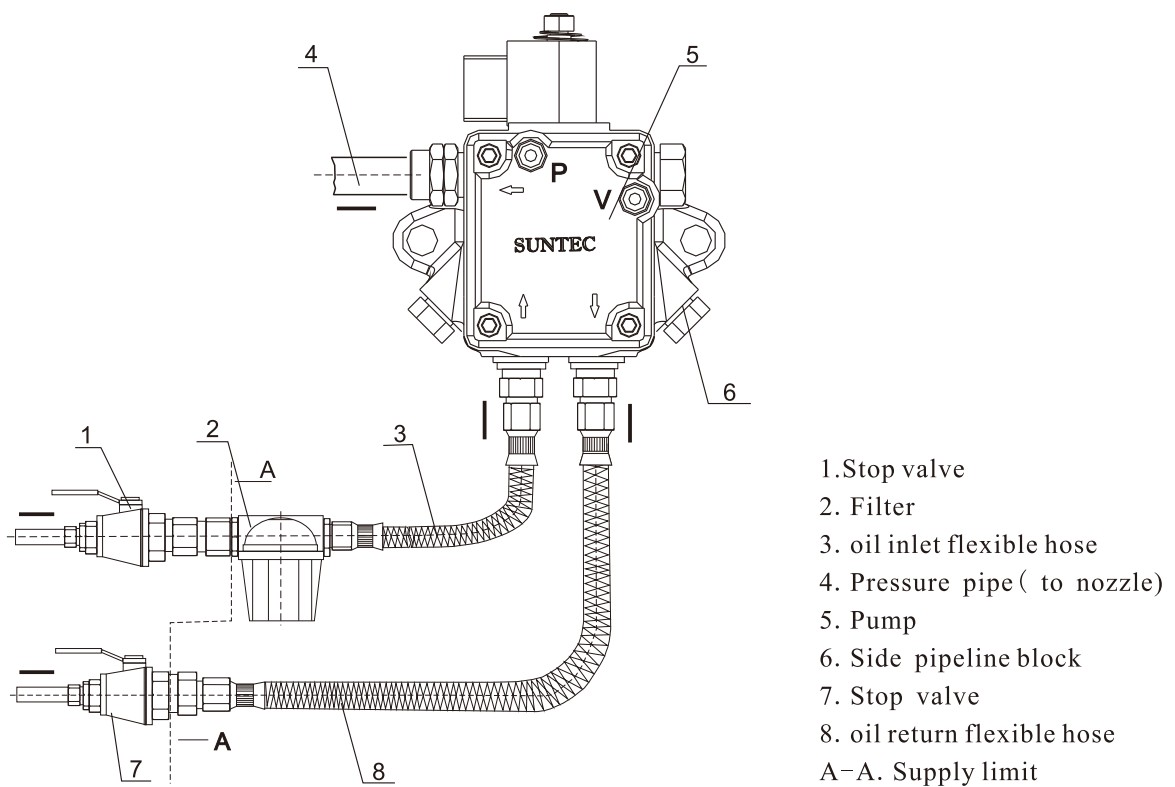

5. 3. CIRCUIT CONNECTION

Burner must follow the supplier wiring diagram to connection, Abide by standard and local principle.

5.4.OIL SUPPLY DIAGRAM

Oil tank and hose must be installed and avoid to cool oil below coagulation point. Oil coagulation point is depended on oil quality. If oil cools to point, then valve and filter will be blocked. the best oil temperature is +15. . . +25°C .

Note! Burner input oil viscosity must be 4-12mm²/S(cSt).

Other viscosity Max. pipeline length can be reached by proportion formula. Such as in the table, the viscosity is 20mm²/S (cSt), the pipe length, then the range value multiplies by 20, divide viscosity, The pipe must be fastened before installed . if oil leaks, it will spray to boiler . so it suggests to use ball valve, oil inlet must locates above 15cm from oil cylinder bottom.

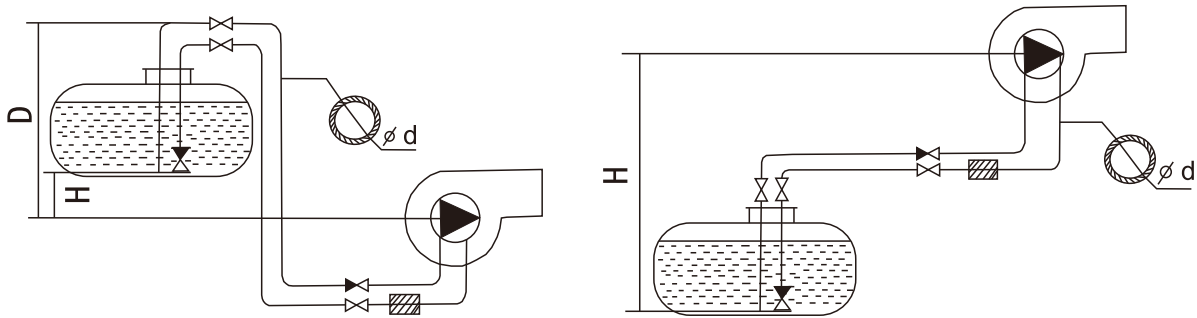

Top oil cylinder

| H m | SUNTEC AS/AN (Ødmm) | | | |
|-----|----------------------|--------|--------|--------|
| | Ø10 mm | Ø12 mm | Ø14 mm | Ø16 mm |
| 0 | 11 | 24 | 46 | 80 |
| 0.5 | 12 | 27 | 51 | 90 |
| 1.0 | 14 | 30 | 57 | 99 |
| 2.0 | 17 | 36 | 68 | 118 |
| 3.0 | 20 | 42 | 79 | 136 |
| 4.0 | 22 | 48 | 90 | 155 |

2850 rpm, 20mm²/s(cSt)
Dmax =15m
(D-H)max=4.5m

down oil cylinder

| H m | DANFOSS BFP21R3 / 5 (Ød mm) | | |
|-----|------------------------------|-------|--------|
| | Ø6 mm | Ø8 mm | Ø10 mm |
| 0 | 17 | 53 | 100 |
| 0.5 | 19 | 60 | 100 |
| 1.0 | 21 | 66 | 100 |
| 2.0 | 25 | 79 | 100 |
| 3.0 | 29 | 91 | 100 |
| 4.0 | 33 | 100 | 100 |

2850 rpm, 20mm²/s(cSt)
Hmax=4.5m

| H m | DANFOSS BFP21R3 / 5 (Ød mm) | | |
|-----|------------------------------|-------|--------|
| | Ø6 mm | Ø8 mm | Ø10 mm |
| 0 | 17 | 53 | 100 |
| 0.5 | 15 | 47 | 100 |
| 1.0 | 13 | 41 | 99 |
| 2.0 | 9 | 28 | 68 |
| 3.0 | 5 | 15 | 37 |
| 4.0 | 1 | 3 | 6 |

2850 rpm, 20mm²/s(cSt)
Hmax=4.5m

| H m | SUNTEC AS/AN (Ømm) | | | |
|-----|---------------------|--------|--------|--------|
| | Ø10 mm | Ø12 mm | Ø14 mm | Ø16 mm |
| 0 | 11 | 24 | 46 | 80 |
| 0.5 | 9 | 21 | 41 | 71 |
| 1.0 | 8 | 18 | 35 | 61 |
| 2.0 | 5 | 12 | 24 | 42 |
| 3.0 | 2 | 6 | 13 | 24 |
| 4.0 | 0 | 0 | 2 | 5 |

2850 rpm, 20mm²/s(cSt)
Dmax =15m
(D-H)max=4.5m

5.5. Pump

SUNTEC Pump

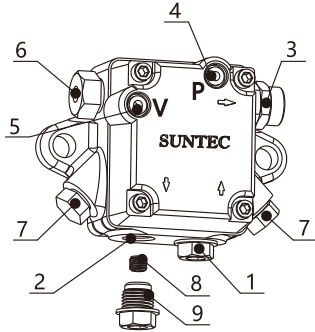

AN...C series

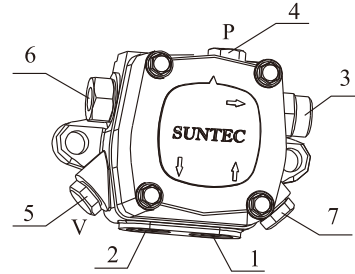

AJ Series

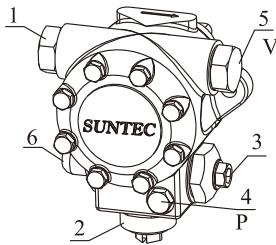

J6/J7CCC Series

- | | | |
|---|------------------------------|----------|
| 1. Oil inlet | 5. Vacuum gauge terminal | 9. Block |
| 2. Oil return inlet | 6. Pressure adjustment screw | |
| 3. Oil outlet | 7. Clean exhaust hole | |
| 4. Pressure gauge terminal G ¹ / ₈ " / exhaust | 8. Inner recycle screw | |

Burner thermal output is decided by pump pressure and nozzle size .There has inner pressure regulator.

Pump inlet pressure :-0.45~0.45Bar

Oil move viscosity :4-12mm²/s(cst)

PUMP PRESSURE REGULATION

Regulating oil pressure by adjustment screw.Rotating clockwise forward=raise screw.vice verse .

Pump setting pressure:

BTN55LR : 10Bar

BTN85-250LR : 12Bar

PUMP EVACUATION

To evacuate the pump,open evacuate nut(4) or pressure gauge inlet,after a time of burner running ,air will come out to end, change the nut and refasten .

6. BURNER OPERATION

6.1. Controlling panel

There has control switch and fault light connecting outside burner, but fault reset button is in the burner controller. Open power switch, start process begins. then comes the prepurge process air damper is fixed the position. at the same time. motor runs.

When prepurge is finished, the first stage fire 1 solenoid valve opens. nozzle oil is sparked by arc, controller controls ignition time, burner works under first stage fire. Controller works from start to end.

If there has no flame during safety time, controller will be locked, burner stops work. fault light will be on .after 15s, press reset button. If the flame is off ,controller will lock in flame failure. the solenoid valve will close. If there has no flame forms, controller will lock in flame failure location. fault red light will be on . burner stops working.

The boiler temperature or pressure exceeds second fire controlling device original setting value. burner will be worked at first stage fire.

The boiler pressure or temperature is lower than the second fire setting value, burning air flow is raised ,solenoid valve(2) opens, as well as the hydraulic air damper axis .driving the block board to second fire location . Burner will runs at second fire .

When the boiler pressure or temperature exceeds second stage fire setting value, burner will turn to first stage

When the boiler pressure or temperature lower than first stage fire setting value, burner will close .

Power On-Off

Burner will cut power automatically . burner stops work.

Reset --control

If burner occurs problem ,reset and restart.

Fault light

Burner has any problem, fault light will be on .

6.2. One Stage Fire Burner BTN40L Working Principle

When load controller requests heating, burner starts, control system (4) begin start indication (photocell (6) detects) . motor (3) runs (time delay/LOA24) . Here comes the prepurge. transformer (7) works after finishes the prepurge process. arc forms in electrodes (8) , solenoid valve (10) opens, pump pressure make oil to nozzle (11) , fire comes out. burner runs under load controller (5) and controlling system (4) watching.

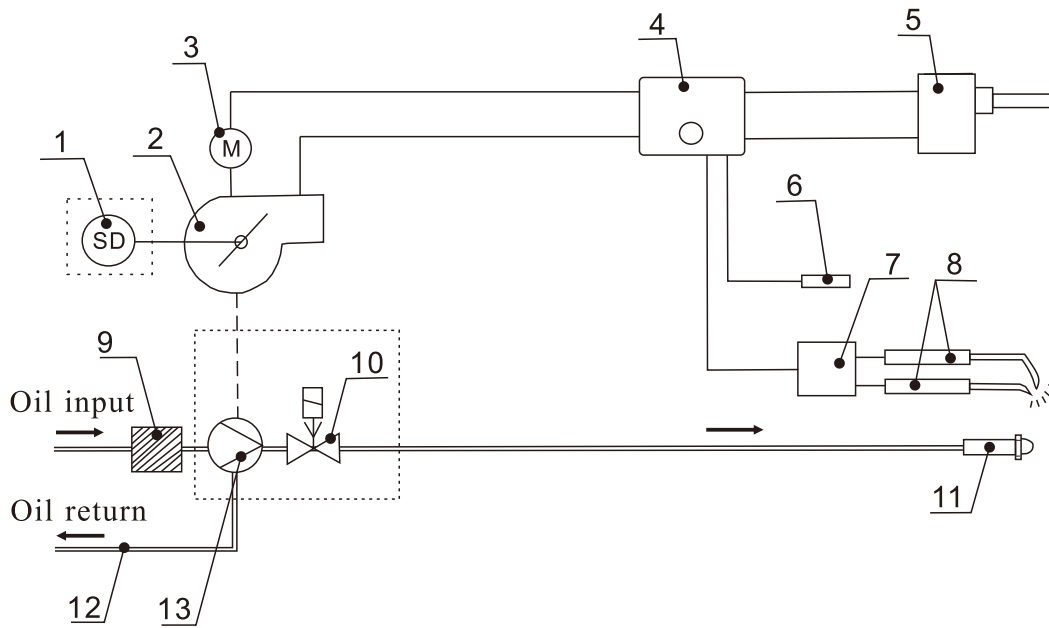

- | | | |
|----------------------|----------------|---------------------|
| 1. Manual air damper | 6. Photocell | 10. Oil valve V1 |
| 2. Fan motor | 7. Transformer | 11. Nozzle |
| 3. Burner motor | 8. EElectrodes | 12. Oil return pipe |
| 4. Controller | 9. Oil filter | 13. Oil pump |
| 5. Load controller | | |

| | |
|---------|---|
| Notice! | Pump oil return will have oil flow when fan motor starts. It must follow oil supply diagram to connect the fuel system. |
|---------|---|

6.3. Two Stage Fire Burner BTN40-250LR Working Principle

When load controller(5) requests heating, burner opens,controlling system(4)start signal starts .motor(3) begins the prepurge.after finishing the prepurge,transformer(7) forms the spark between the electrode(7).one stage fire solenoid valve(10)V1 opens,pump(13) deliveries the oil to nozzle(11). After 11s of first stage fire,hydraulic air damper(1) runs to full load,at the same time ,second stage fire solenoid valve (14) V2 opens ,high fire is on .During burner working ,load controller controls system(4) and solenoid valve(10.14).pump pressure drives the hydraulic air damper,following the request of part load and full load to adjust the block board.If burner stops work ,solenoid valve (10 and 14)close,the block board stops at low fire location.

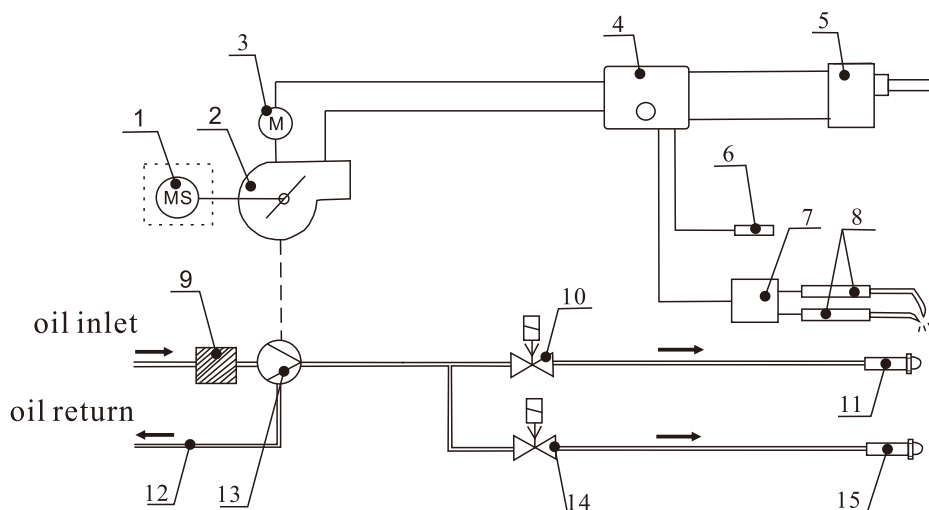

- | | | |
|------------------------|----------------------|-----------------------|
| 1.Hydraulic air damper | 6.Photocell | 11.Nozzle (low fire) |
| 2.Fan motor | 7.Tranformer | 12.Oil return pipe |
| 3.Motor | 8.Electrode | 13.Pump |
| 4.Controlling system | 9.Filter | 14.Solenoid valve V2 |
| 5.Loild controller | 10.Solenoid valve V1 | 15.Nozzle (high fire) |

Notice!

When burner fan motor starts ,the pump oil flows.

7. Burner Head Setting

7.1. BTN40-55LR Air Adjustment In Burner Head

Rotating adjustment screw 4, adjustment block ring moves along "+" "-" direction to change the distance of ring and air diffuser. it will lead to the adjustment of air channel "a" air flow and rate. the original setting of graduation is 4. the biggest openness .

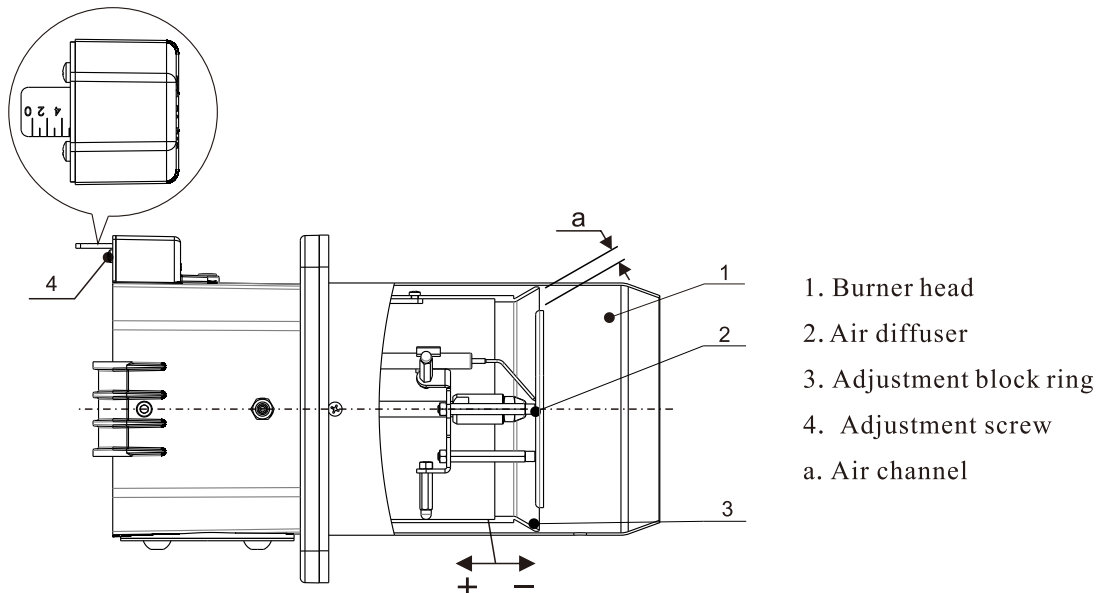

7.2. BTN85-250LR Air Adjustment In Burner Head

Rotating adjustment screw 4, adjustment block ring moves along "+" "-" direction to change the distance of ring and air diffuser. it will lead to the adjustment of air channel "a" air flow and rate. the original setting of graduation is 4. the biggest openness .

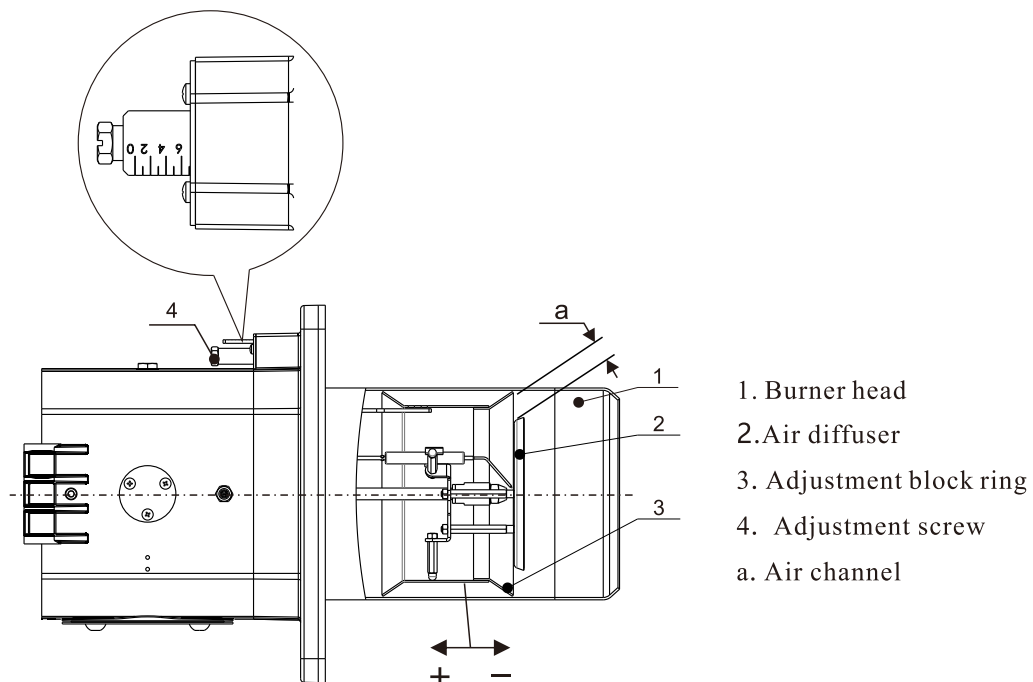

7.3. Removing Oil Sprayer

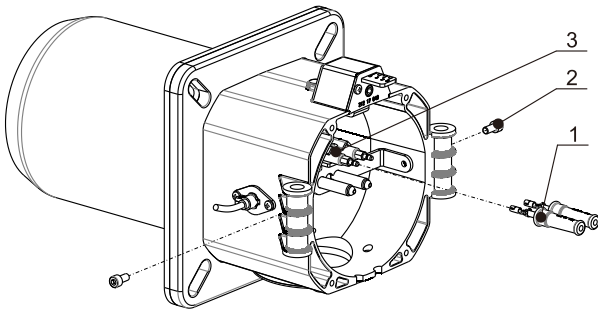

Open hinge,remove two pcs high power cable(1),then take out the 6 angles screw(2),as well as the oil sprayer(3).Installing it in opposite direction.

7.4. Electrode Location Adjustment

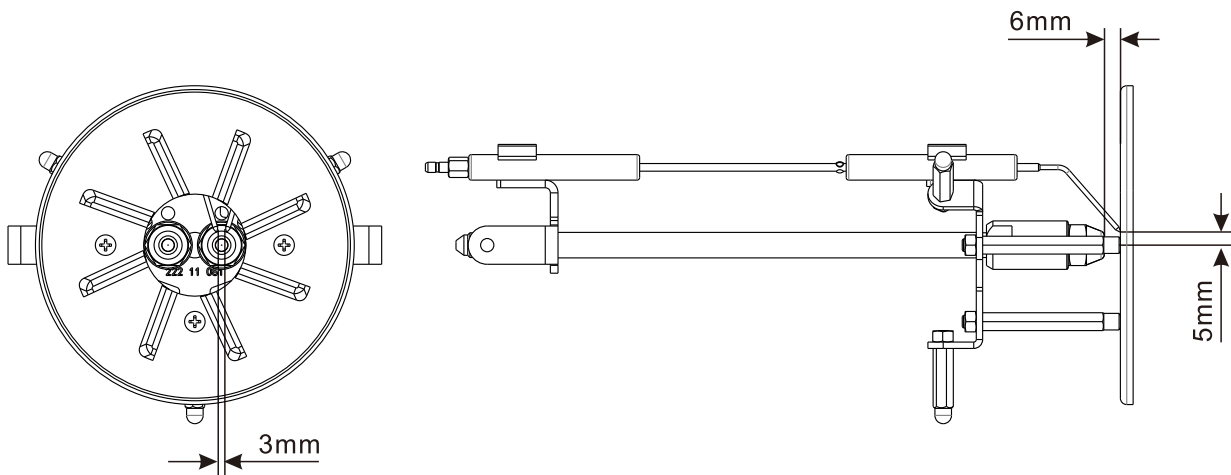

7.5. Air Damper Adjustment Mechanism

1. BTN40 ~ 55L Burner

BTN40 ~ 55L is one stage fire burner, only one air damper openness, it adjusts the air damper manually.

Like dia. loose lock nut(1), rotate adjustment board(2).
move along "+" direction to increase the air .vice verse .
then fasten the lock nut(1) in right way.

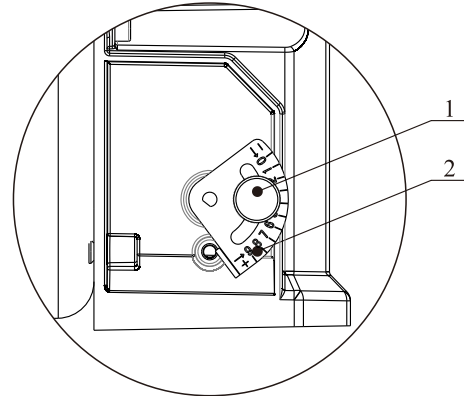

1.Lock nut
2.Adjustment board

2. BTN40 ~ 250LR hydraulic cylinder to adjust air damper.

As Dia. The air flow adjustment for one stage fire burning .
Take out the cap(1), use straight screwdriver to twist the
one stage fire adjustment mandrill(2) along the "+" direction.
then the air flow will rise ,vice verse. After finishing ,
cover the cap(1).

The air flow adjustment for one stage fire burning .

Loose two stage fire adjustment mandrill(3) nut, use
crossdriver to twist the mandrill along "+" direction,
it will raise the air flow ,vice verse. at last fasten the lock nut.

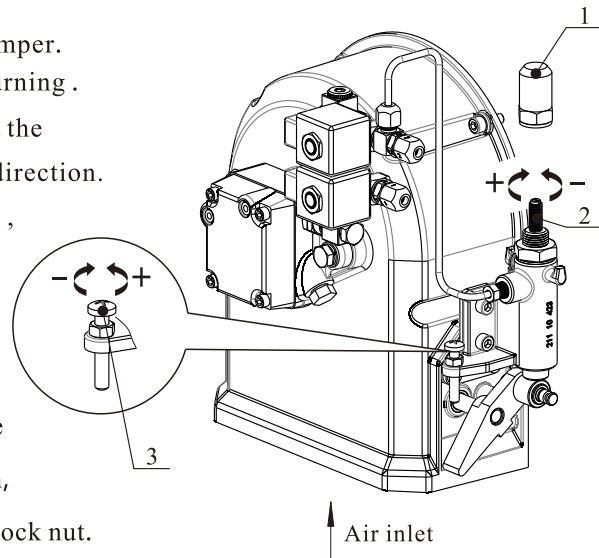

1. Top cap
2. one stage fire adjustment mandrill
3. Two stage fire adjustment mandrill

8. CONTROLLING SYSTEM

8.1. LOA24...Oil controlling system

Timing sequence diagram(control process)

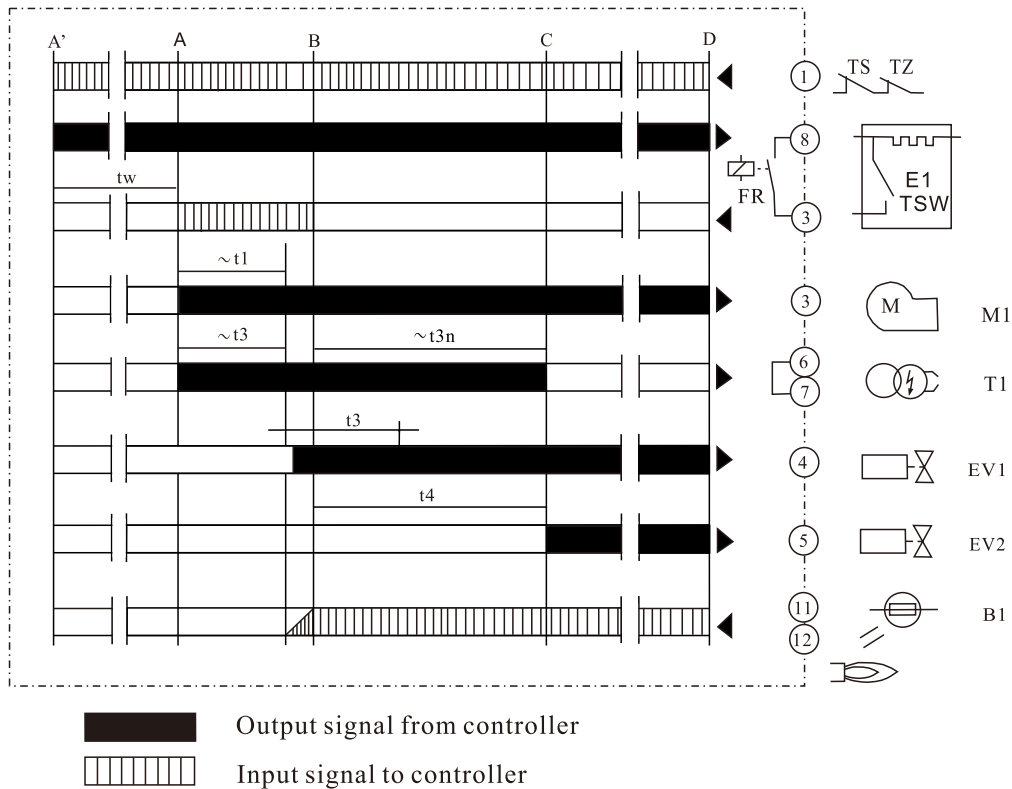

CODE

TZ Temperature limiter
 TS Temperature controller
 E1 Pre-heater
 TSW Temperature controller of pre-heater
 M1 Motor
 T1 Transformer
 EV1 Solenoid valve
 B1 photocell/flame signal

| | | |
|-----|---|------------|
| tw | Preheater heats time to contactor "OW" releasing ready signal | about 1min |
| t1 | Pre-purge time | about 13S |
| t3 | Pre-ignition time | about 3S |
| t3n | Post-ignition time | about 15S |
| t2 | Stabilization | max 10S |
| t4 | The photocell and terminal 5 voltage released time interval | about 15S |
| --- | Flame failure reaction time | < 1S |

A' With oil heater burn starts
 A Without oil heater burn starts
 B The time of flame detected (burner starts)
 C Controller is in normal position (control process finishes)
 D Temperature controller TS closes



CONTROL FUNCTION IN FAILURE

Extra brightness/early flame signal

Pre-purge process /pre-ignition process does not allow to have the flame signal.If there happens oil valve leaks,extra brightness,photocell or its coil will short circuit.flame amplifier failure etc , these conditions will release signal,then controller will lock in prepurge failure time.oil valve will not open .

No Flame Signal

There has no flame signal when stable time is finished,controller will lock immediatel .

Flame shut off during running

Controller will cut off fuel supply and try to restart it by itself when flame shuts off,"t4" finishes, controller runs all start process.

Along lock control output 3to 8,terminal 11 will reduce pressure in 1s,lock remote signal terminal 10 receives voltage,reset control after locks.at least 50s.

Low voltage protection

Electrical protection equipment prevents low voltage,make sure that when main return line in low voltage(\square 165V)shows dangerous fault lead to controller closing burner and stop new start.

Controller technical parameters

| | |
|------------------------------|------------------------------------|
| Supply voltage | 220 VAC-15% . . . 240VAC \pm 10% |
| Low voltage protection | \square 165 V |
| Frequency | 50-60 Hz, \pm 6% |
| External fuse | max.10A |
| Allowed combient temperature | -20. . . +60 \square |

Flame detection current

| | | |
|--|--------------------------|----------------|
| Photocell QRB | 220 VAC | 240 VAC |
| Min.requested photocell current as flames being on | 65 μ A DC | 75 μ A DC |
| Max. requested photocell current as flames being off | 5 μ A DC | 6 μ A DC |
| Max. requested photocell current as flames being on | 200 μ A DC | 220 μ A DC |
| d.c.Measurement equipment resistance | max. 5kOhm (+terminal12) | |

8.2 LMO...controller

Timing sequence diagram(control process)

Connection diagram and internal diagram LMO24...

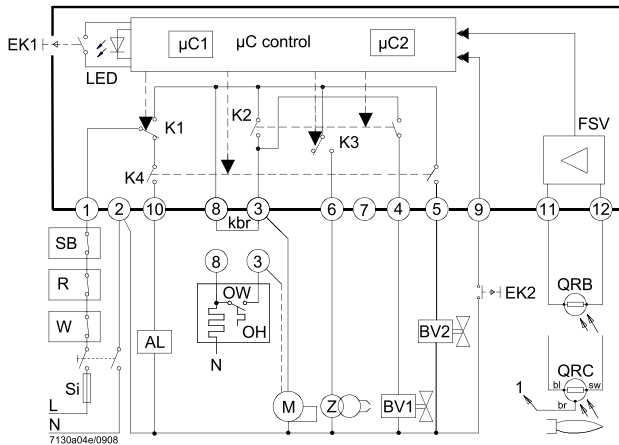

Control sequence LMO24...

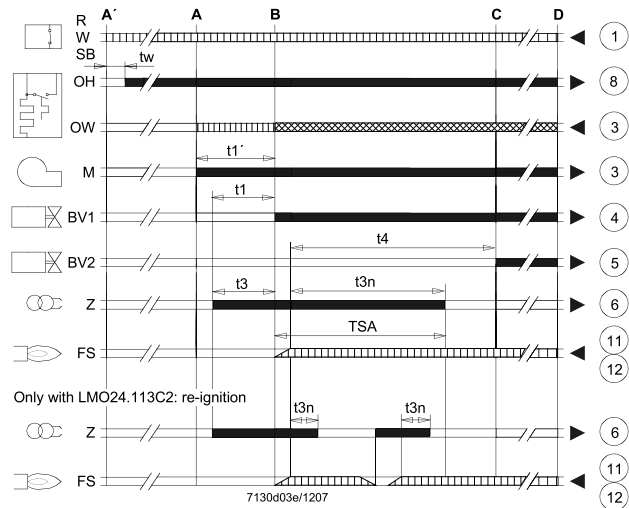

Connection diagram and internal diagram LMO44...

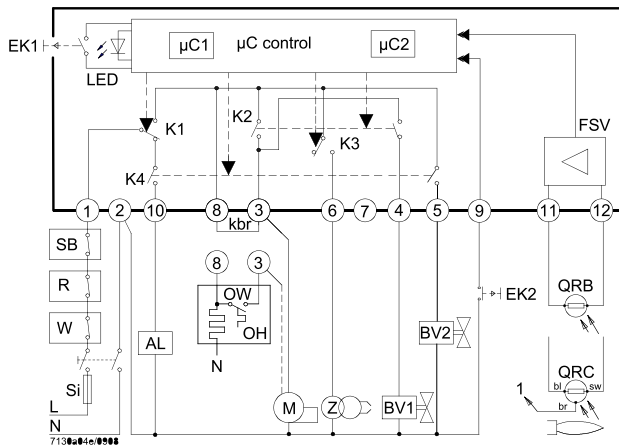

Control sequence LMO44...

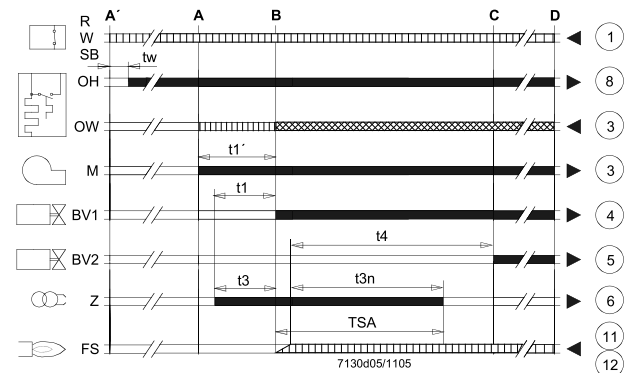

Code name

| | | | | | | | |
|-------|--|--------|--|-----|--|---|--|
| AL | Alarm device | M | Burner motor | TSA | Ignition safety time | A | Start of startup sequence with burners using no oil preheater (OH) |
| BV... | Fuel valve | OW | Release contact of oil preheater | tw | Waiting time | B | Time of flame establishment |
| EK1 | Alarm device | OH | Oil preheater | t1 | Prepurge time | C | Operating position |
| EK2 | Remote lockout reset button | QRB... | Photo resistive flame detector | t1' | Purge time | D | Controlled shutdown by control thermostat or pressurestat® |
| FS | Flame signal | QRC... | Blue-flame detector bl = blue, br = brown, sw = black | t3 | Preignition time | | Control signals |
| FSV | Flame signal amplifier | R | Control thermostat or pressurestat | t3n | Postignition time | | Control signals |
| K... | Contacts of control relay | SB | Safety limit thermostat | t4 | Interval from flame signal to release of fuel valve 2 (Bv2) | | Perm. input signals |
| kbr | Cable link (required only when no oil preheater is used) | Si | External primary fuse | A' | Start of startup sequence with burners using an oil preheater (OH) | | Microcontroller1 |
| LED | 3-color signal lamp | W | Limit thermostat or pressure switch | | | | μC1 Microcontroller2 |
| | | Z | Ignition transformer | | | | μC2 |

Function

Preconditions for startup

- Burner control is reset
- Reset button «EK1» or «EK2» not used
- All contacts in the line are closed and there is demand for heat
- No undervoltage
- Flame detector is darkened and there is no extraneous light

Undervoltage

- Safety shutdown from the operating position takes place should mains voltage drop below about AC 165V($U_N=AC\ 230V$) or AC 75V($U_N=AC\ 120V$)
- Restart is initiated when mains voltage exceeds about AC 175V($U_N=AC\ 230V$) or AC 95V($U_N=AC\ 120V$)

Time supervision oil preheater

If the oil preheater's release contact does not close within 10 minutes, the burner control will initiate lockout.

Controlled intermittent operation

After no more than 24 hours of continuous operation, the burner control will initiate automatic controlled shutdown followed by a restart.

Control sequence in the event of fault

If lockout occurs, the outputs for the fuel valves, the burner motor and the ignition equipment will immediately be deactivated (<1 second). In the event of lockout, the LMO... remains locked and the red signal lamp (LED) will light up. The burner control can immediately be reset. This state is also maintained in the case of mains failure.

| Cause | Response |
|--|---|
| Mains failure | Restart |
| Voltage has fallen below the undervoltage threshold | Safety shutdown, followed by restart |
| Extraneous light during prepurge time (t_1), 5 s before fuel valve (BV1) release | Lockout at the end of prepurge time (t_1) |
| Extraneous light during waiting time (t_w) | Prevention of startup, lockout after 40 seconds at the latest |
| No flame at the end of safety time (TSA) | Lockout at the end of safety time (TSA), blink code 2 |
| Loss of flame during operation | Max. 3 repetitions, followed by lockout |
| Oil preheater's release contact does not close within 10 minutes | Lockout |

Resetting the burner control

When lockout occurs, the burner control can immediately be reset. To do this, press the lockout reset button for about 1 second (<3 seconds). The LMO... can only be reset when all contacts in the line are closed and when there is no undervoltage.

Ignition program with LMO14.113×2 and LMO24.113×2

If the flame is lost during safety time (TSA), the burner will be reignited, but only until the end of safety time (TSA). This means that several ignition attempts can be made during safety time (TSA) (see Control sequence).

Limitation of repetitions

If the flame is lost during operation, a maximum of 3 repetitions can be made. If the flame is lost for the fourth time during operation, the burner will initiate lockout. The repetition count is restarted each time controlled switching on by control thermostat or pressurestat (R) takes place.

Operation, display, diagnostics

Operation



Lockout reset button «EK» is the key operating element for resetting the burner control and for activating/deactivating the diagnostic functions.



The multicolor signal lamp(LED)in the lockout reset button is the key indicating element for both visual diagnostics and interface diagnostics.

Both «EK» and LED are located under the transparent cover of the lockout reset button.

There are 2 diagnostic choices:

1. Visual diagnostics:Operational status indication or diagnostics of the cause of fault.
2. Interface diagnostics:With the help of the interface OC1400 and PC software ACS400/ACS410 or flue gas analyzers of different makes .

Visual diagnostics:

In normal operation,the different operating states are indicated in the form of color codes according to the color code table given below.

Operational status indication

During startup,status indication takes place according to the following table:

Color code table for multicolor signal lamp(LED)

| Status | Color code | Color |
|---|-----------------------|-------------------|
| Waiting time «tw» ,other waiting states | ○..... | Off |
| Oil preheater on | ●..... | Yellow |
| Ignition phase,ignition controlled | ● ○ ● ○ ● ○ ● ○ ● ○ ● | Flashing yellow |
| Operation,flame o.k. | □..... | Green |
| Operation,flame not o.k. | □ ○ □ ○ □ ○ □ ○ □ ○ | Flashing green |
| Extraneous light on burner startup | □ ▲ □ ▲ □ ▲ □ ▲ □ ▲ | Green-red |
| Undervoltage | ● ▲ ● ▲ ● ▲ ● ▲ ● | Yellow-red |
| Fault,alarm | ▲..... | Red |
| Error code output(refer to «Error code table») | ▲○ ▲○ ▲○ ▲○ ▲○ | Flashing red |
| Interface diagnostics | ▲ ▲ ▲ ▲ ▲ ▲ ▲ ▲ | Red flicker light |

Legend

..... Steady on
○ Off

▲ Red
● Yellow
□ Green

Diagnosis of cause of fault

After lock-out, the red fault signal lamp remains steady on. In that condition, the visual diagnosis of the cause of fault according to the error code table can be activated by pressing the lock-out reset button for more than 3 seconds. Pressing the reset button again for at least 3 seconds, the interface diagnosis will be activated (for more detailed information, refer to data sheet 7614).

The following sequence activates the diagnosis of the cause of fault:

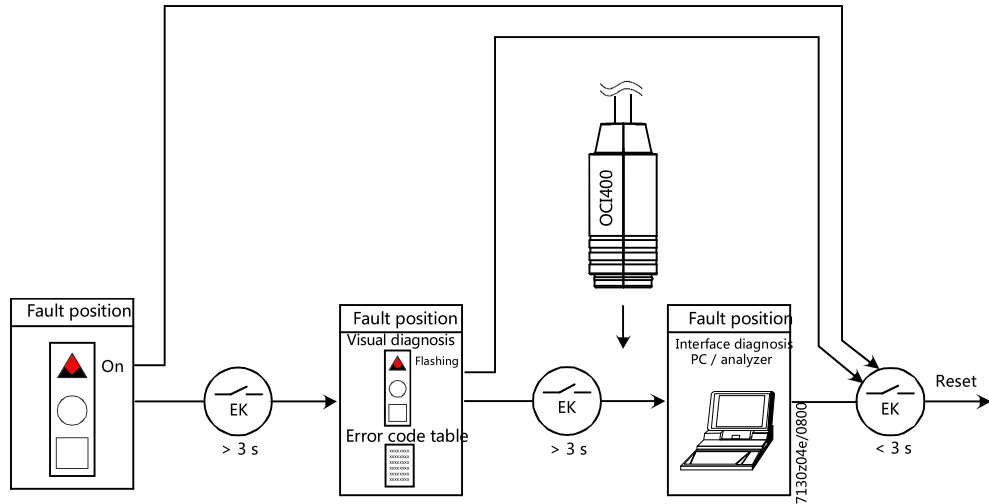

| Error code table | |
|------------------|---|
| Blink code | Possible cause |
| 2 blinks • | No establishment of flame at the end of «TSA» - Faulty or soiled fuel valves - Faulty or soiled flame detector - Poor adjustment of burner, no fuel - Faulty ignition |
| 3 blinks • | Free |
| 4 blinks • | Extraneous light on burner start-up |
| 5 blinks • | Free |
| 6 blinks • | Free |
| 7 blinks • | Too many losses of flame during operation (limitation of the number of repetitions) - Faulty or soiled fuel valves - Faulty or soiled flame detector - Poor adjustment of burner |
| 8 blinks • | Time supervision oil pre-heater |
| 9 blinks • | Free |
| 10 blinks • | Wiring error or internal error, output contacts |

- During the time the cause of fault is diagnosed, the control outputs are deactivated.
- Burner remains shut down
 - Fault status signal «AL» at terminal 10 is activated

The diagnosis of the cause of fault is quit and the burner switched on again by resetting the burner control.

Press lock-out reset button for about 1 second (< 3 seconds).

9.MAINTENANCE



Warning! Cut off power before burner maintenance, also close oil supply pipe manual stop valve. When checking , close burner power, but open oil supply pipe manual stop valve.

BURNER MAINTENANCE

- *To make sure the good working , it should clean the ignition and check their set.
- *Check photocell position and status.
- *If necessary, clean the filter(at least once per year).
- *If nozzle damages , change it .
- *Clean dirty and float waste, keep burner clean.
- *Regularly do the smoke measurement to check burning speciality.
- * Check burning value by smoke analysis(such as after full oil cylinder or once per year)

HEATING EQUIPMENTS CONTROL

- *Keep boiler clean and door closed
- *Guarantee heating system has enough water pressure
- *Clean fire oven and chimney regularly
- *Check smoke board adjustment regularly
- *Avoid water spray into burner
- *Boiler must open vent fan
- *Clean the oil tank ,at least once per 4-5 years
- *Check boiler work

10. FAILURE AND MEASUREMENTS

Failure, firstly check below items :

1. Check circuit (control and supply voltage)
2. Check valve leakage detector (Yellow light is ok)?
3. Check all adjustment device and controller installation.
4. The working of safe devices.
5. Check the burner if has fuel and fuel pipe valve is open or not, oil tank has oil or not.

If failure isn't caused by above items, have to check each part function. If controller is on "Lock" (signal light is on), need to reset. When controller turns to start position, burner opens. watch burner function. Indicator signal show some failure kind.

| Notice | Cause | Measurements |
|---|--|--|
| 1. Start failure | | |
| Motor does not start. | Main oil return closed Motor overload relay releases or failure Fuse broken Motor contactor failure Motor control return line cut off: -controller failure Photocell short circuit | Find out the cause and amend. Check and set, reset or start. reset or change Change Change Repair or change |
| 2. Ignition failure | | |
| Motor starts, there has control voltage from controller to transformer, no ignition. after a while, lock happens. | Electrode is dirty or old, insulation part cracks. □ Wrong position of electrode ignition cable damages Transformer failure Controller failure Transformer cable loosen or damage | Clean and change adjustment change change change change or repair |

| Notice | Cause | Measurement |
|---|--|---|
| Burner motor statrm,spark comes out,after a short while, lock. | Solenoid valve not works -Solenoid valve or coil failure ,cable damages --controller failure | Change damaged parts |
| Nozzle no oil | Oil atomizing pressure is too low Nozzle blocks or damages | Adjustment |
| 4. Oil pump | | |
| No supply oil or atomizing pressure is too low.Nozzle no oil.Big mechanical noise | Filter dirty oil intake pipe leaks Pump load reduces -Pumps failure or damage valve does not open to nozzle --Solenoid valve(AS47A) does not close --Solenoid valve(other pump)does not open | Clean Seal Change Change Change solenoid valve coil or pump Fasten connector |
| 5. Lock after flame is built | | |
| Lock happens after burner runs serval seconds. then restart. | Wrong burner adjustment Dirty filter Nozzle block Solenoid valve failure | Correct adjustment Clean Change Change |
| 6. Too early of flame signal | | |
| Motor starts , then lock occurs | Oil valve leaks | Clean or change |

| Notice | Cause | Measurement |
|--|---|--|
| 7.Photo cell failure(lock) | | |
| Burner motor starts, flame comes out, then lock happens. | Wrong photocell position Dirty photocell Weak flame brightness Photocell failure | Adjustment Clean Burner adjustment Change |
| Lock in prepurge process | Controller failure There has heavy oil or heavy carbon deposit in burner head | change clean and adjustment |
| Lock in close process | Photocell failure or damages Controller failure Extra brightness cause wrong flame signal | change change find out and amends. |
| 8.BURNER HEAD | | |
| Inner over oil or heavy carbon deposit | Wrong distance between air diffuser and nozzle Wrong adjustment of combustion supporting air There has no vent in boiler Wrong nozzle size or model Old-aged nozzle Wrong adjustment ring position | Correct adjustment Adjustment Increase air supply Change nozzle change Adjustment |

11. Wiring Diagram

11.1 BTN40-55L Wiring Diagram

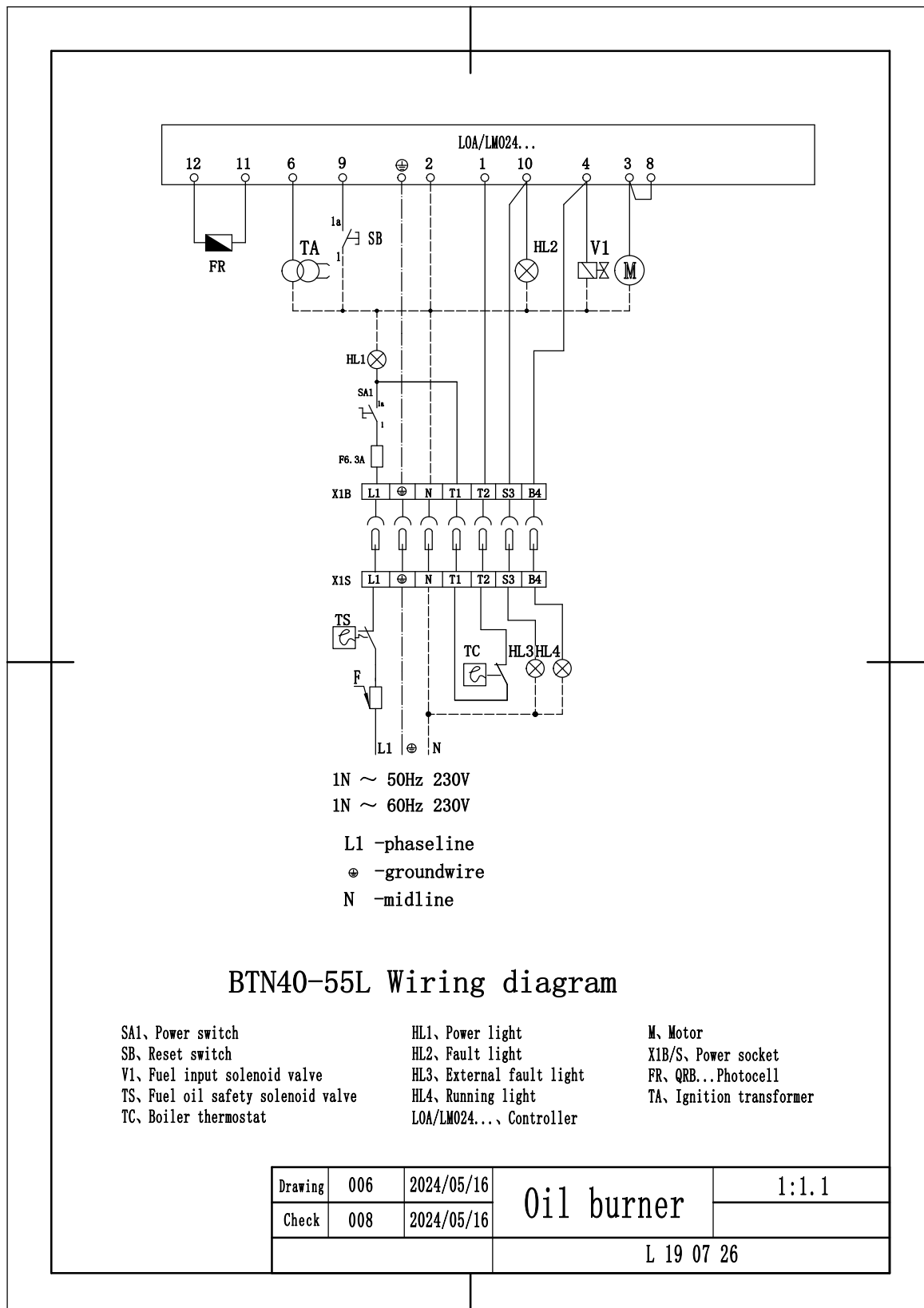

11.2 BTN40-55LR Wiring Diagram

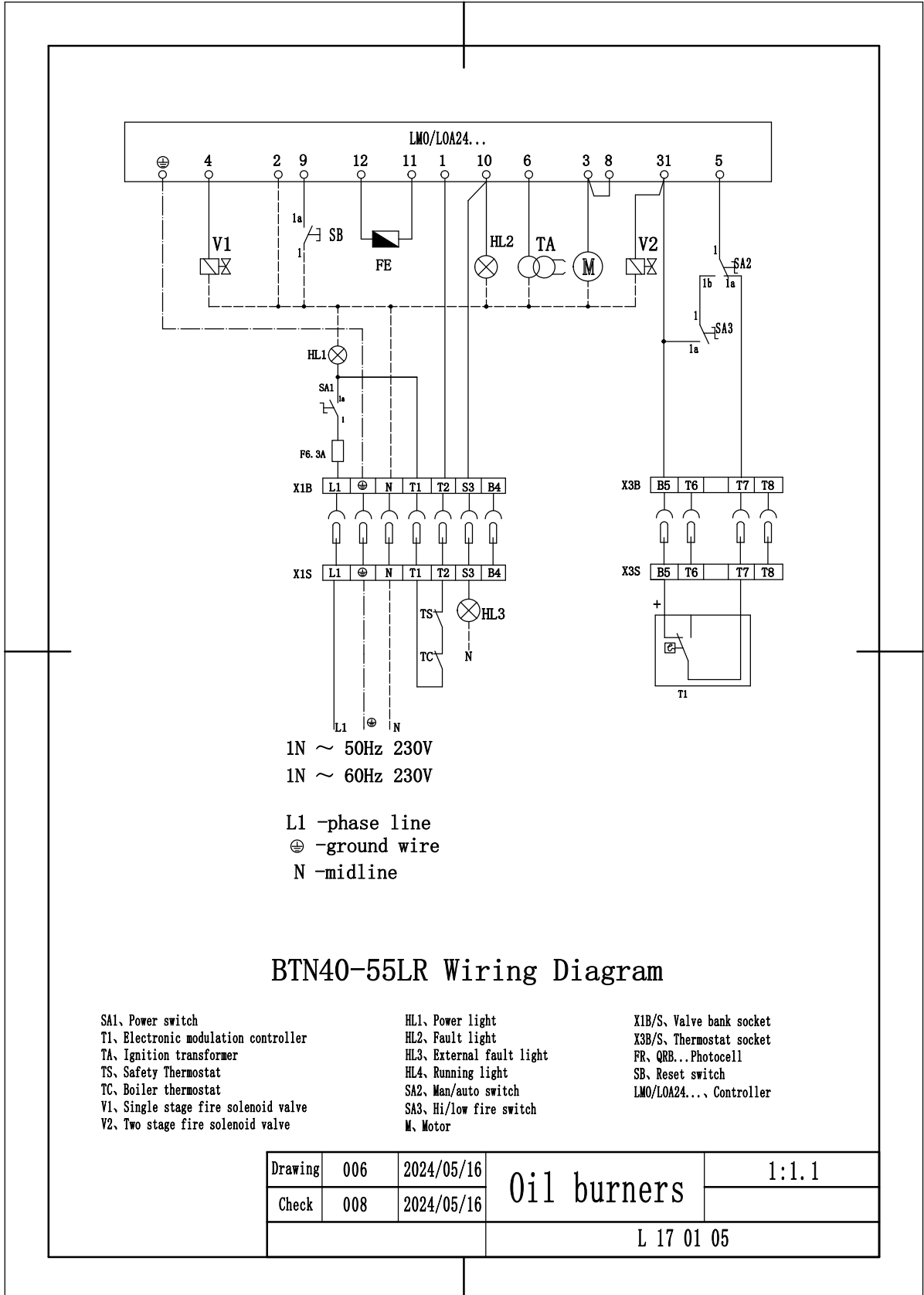

11.3 BTN85-250LR Wiring Diagram

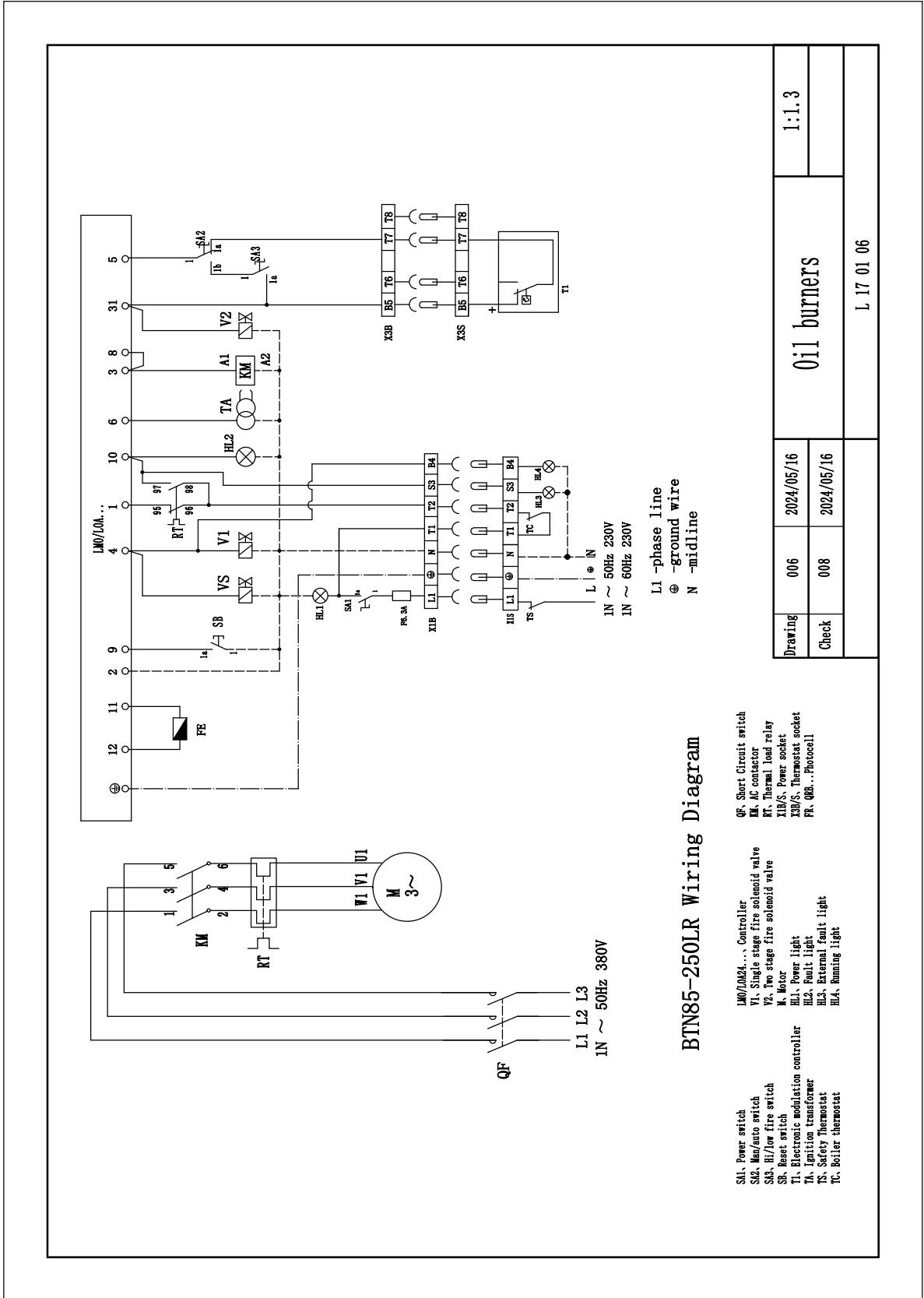

SERVO GLOBAL HEATING TECNOLOGY

